

# PUMPS FOR WASTE WATER SYSTEMS



SUBMERSIBLE PUMPS FOR WASTEWATER AND SEWAGE

K and KX series | Discharge connector DN 200 - DN 500





## HOMA: QUALITY PRODUCTS FOR WASTE WATER SYSTEMS

### HIGH EFFICIENCY AND ECONOMIC VIABILITY

Submersible pumps from HOMA have been in use around the world for decades. Requirements for the waste water sector are constantly increasing. HOMA products go beyond state of the art – through the continual optimisation of their hydraulic components and motors, they ensure economic operation and an affordable purchase price. All of the company's expertise and creative potential have been incorporated into its products and services – for maximum customer benefit.

### INDIVIDUAL POSSIBILITIES, OPTIMUM SOLUTIONS

HOMA unites safety, economic viability, high quality and robust system technology with customisation options: the product spectrum ranges from complete pump stations with pumps, valves, pipework, pre-assembled concrete or plastic sumps, through to electronic control systems. The focus is on optimum design with cost effective workflows on site for all installation types.

### HIGHER FUNCTIONAL RELIABILITY, LOWER ENERGY CONSUMPTION

With HOMA you are always in good hands – our pump stations are controlled and monitored fully automatically, and faults are registered automatically, too. The pumps run with the lowest possible energy consumption, which is also ensured by optimally matched water level control devices, such as floats, pneumatics, ultrasound and hydrostatic level sensors (ENS sensors).

In many cases, both the pump and control system have to meet the relevant requirements and regulations on explosion protection. All HOMA pumps are therefore also available as explosion-proof versions.

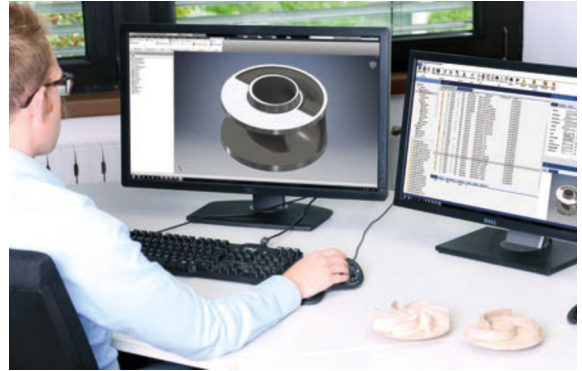

New developments are produced in the HOMA R&D centre on advanced 3D CAD systems.



Before delivery, the finished units are put through their paces in the high tech test centre. This guarantees HOMA quality as you know it.

## PROVEN TECHNOLOGY FOR A BROAD RANGE OF APPLICATIONS

### MULTIPLE DEMANDS – INDIVIDUAL SOLUTIONS

Submersible waste water pumps from HOMA convey domestic, public and industrial waste water, sewage (containing faeces), and sludge (which may contain high levels of solid and fibrous matter), as well as domestic waste water of any kind. Thanks to the use of a broad range of materials (stainless steel in different grades, bronze, Viton, etc.), HOMA submersible pumps are suitable for a wide variety of industrial applications.

- 3 Industrial waste water
- 3 Sewage treatment plants
- 3 Large scale pump stations
- 3 Industrial applications
- 3 Oil and gas
- 3 Power station construction
- 3 Mining
- 3 Chemical processes
- 3 Shipbuilding/offshore sector

### MORE POWER FOR EVERY REQUIREMENT

HOMA pumps are used in all manner of applications: to supply water to power stations, as seepage pumps in coal mines, drainage pumps in infrastructure projects, waste water pumps for industrial waste water, or as ballast pumps in the shipbuilding and marine sector. Customers benefit from proven features tried and tested in real life applications, such as:

- 3 A range of different impellers, depending on the medium being conveyed, e.g. special symmetries, hardened materials and ceramic coatings
- 3 Motors suitable for continuous operation, with or without cooling jackets
- 3 3 3 3 3 3 High grade materials
- 3 Robust construction



## FOR GREATER SAFETY AND DURABILITY

### MORE BENEFITS IN ALL OPERATING MODES

For operating mode S1 (continuous operation), the motors are designed with a maximum switching frequency of 15 operating cycles per hour. In addition to the standard version for operation with a submerged motor, a special version with cooling jacket is also available for use with a surface motor or dry installed motor.

Hydraulics with single-channel impellers are suitable for intermittent operation (i.e. generally for level-controlled automatic sump operation) and continuous operation. Vortex or multi-channel impellers are the right choice for continuous operation in particular, e.g. for industrial service water supply.

### TOP MATERIAL QUALITY – LOWER SUSCEPTIBILITY TO FAILURE

Quality is a measurable value – fully floodable pump blocks from HOMA impress through their generous sizing of all important components, with outstanding material quality and solid mechanical workmanship. This guarantees a long service life.



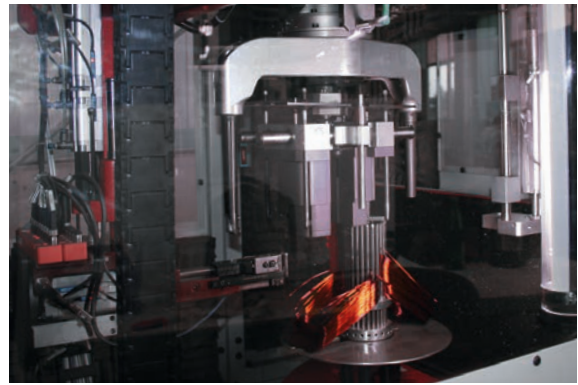

Our own motor winding shop enables production in all voltages and frequencies.

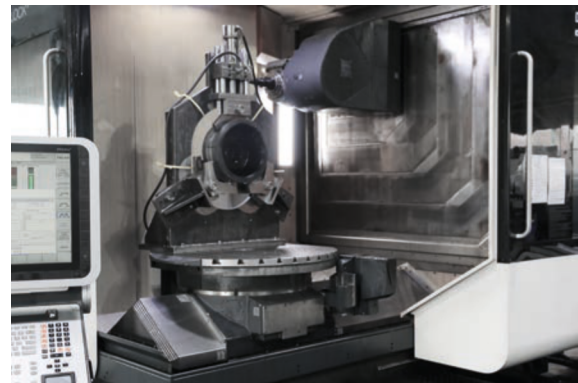

Mechanical processing of all components at our own factory using high tech precision machines results in greater efficiency and flexibility.

## DIFFERENT INSTALLATION TYPES ALLOW GREATER EASE OF SERVICE

### STATIONARY WET WELL INSTALLATION

The pump is connected to the pressure pipe and is made pressure-tight by means of a coupling base attached to the bottom of the sump. For maintenance or repair, it can be removed from its operating position from above through the sump opening via a permanently installed double pipe feed. The pump is attached and detached automatically; it is not necessary to enter the sump. With its flexible rubber gasket, the HOMA coupling system thereby ensures a secure, permanent, leak-free seal between the pump and the pressure pipe.

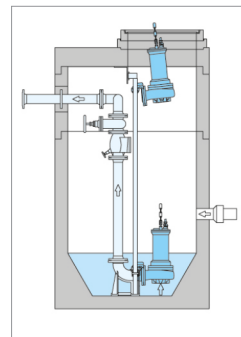

Stationary wet well installation

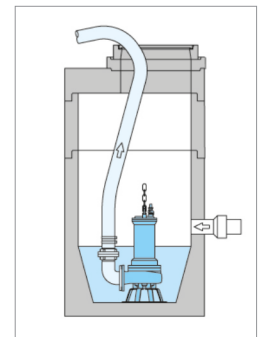

Mobile wet well installation

### MOBILE WET WELL INSTALLATION

Universal installation for immersion in trenches and sumps, for use over a limited period, emergency operation or service operation. Can be used with a pressure hose or pressure pipe.

### STATIONARY DRY INSTALLATION – VERTICAL OR HORIZONTAL

Flood-proof installation for pump stations with a separate collection sump. Flange connection for suction pipe and pressure pipe.

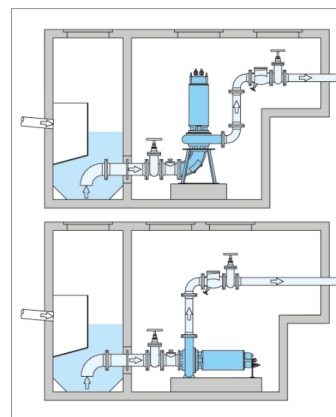



## GREATER RELIABILITY THROUGH INTELLIGENT ACCESSORIES

### VICON: ENSURING A LONG PUMP SERVICE LIFE

Status monitoring of electrical machines is of considerable importance where quality, reliability, energy savings and targeted repair play a significant role. Submersible pumps are a special case since they are immersed in the medium being handled. Carrying out repair and maintenance is often extremely difficult. Furthermore, high reliability without pump downtimes is essential. With HOMA VICON, the pump and system are constantly and reliably monitored, and any faults or damage are detected at an early stage.

For example, HOMA VICON registers any blockage or damage to the hydraulics, unfavourable or defective operating points, and bearing damage or pipework problems, and indicates these issues or, if necessary, switches the pump off. By optimising the system and detecting adverse operating conditions in good time, HOMA VICON helps to save energy and reduce lifecycle costs.



Reliable monitoring – the integral HOMA VICON pump vibration diagnostic system.



For aggressive chemical media: the stainless steel submersible pump range from HOMA.



Final assembly – the last step – also requires the utmost care.

## THE HIGH PRESSURE CLEANING DEVICE FOR THE PUMP SUMP

### FLUSH VALVES: KEEPING IT CLEAN

Pump stations require frequent cleaning as solids settle at the bottom or a layer of floating matter gathers on the surface of the water. Expensive cleaning and maintenance measures as well as high costs due to downtimes can arise. HOMA has the answer: the new HOMA FV 25 and FV30 flush valves reliably prevent deposits in pump sumps. At the beginning of the pumping process, part of the medium being handled is channelled back to the pump sump through the open flush valve. As the medium is flushed through the sump, it stirs up deposited solids so that they can be removed.

The flushing nozzle can either be directed towards the bottom of the pump sump to remove deposits, or alternatively, towards the surface of the waste water to prevent the formation of a layer of floating matter, especially in the case of waste water with a high fat content.



Optionally available with connection for automatic HOMA FV flush valve.



## SERIES AND PUMP TYPES

### MOTOR SELECTION

#### Rotational speeds:

Depending on their hydraulics, the motors are sized for the following rotational speeds.

- 31470 rpm= 4-pole
- 3960-980 rpm= 6-pole
- 3680-740 rpm= 8-pole
- 3590 rpm= 10-pole
- 3490 rpm= 12-pole

#### Voltages:

All performance data refers to an operating voltage of 400 V/3 Ph 50 Hz. Other voltages are available on request.

#### Type of start:

In the standard version, pumps are supplied for direct start and star-delta start.

All motors are available for frequency converter and soft start operation.

#### Explosion protection:

Depending on component assembly, also available as explosion-proof versions in accordance with Directive 2014/34/EU for equipment group II, category 2G, gas group IIB and temperature class T4(T3).

#### Dry installation:

In addition to the standard version for immersion, all motors are also available for dry installation with cooling jacket.

#### Motor monitoring:

All motors are supplied with temperature sensors in the winding, bi-metallic sensors (standard), PTC thermistor or PT100 (on request).

#### Motors for wet well installation:

With oil chamber monitoring probe. With moisture monitoring of the cable connection chamber (for the engines P EX, F + F EX, G + G EX). Optionally with moisture monitoring of the stator chamber (version S).

#### Motor with cooling jacket:

Supplied as standard with oil chamber monitoring probe.

Additional monitoring devices (bearing temperature, stator room moisture) on request.



# KEY TO DESIGNATIONS

Series	Impeller design	Discharge connector	Ball passage	Impeller diameter	Motor size	Water-cooled motor	Motor input	Rotational speed	Monitoring	Explosion-proof motor
Pump					Motor					
	<b>K(X)</b>									
	K, KX Closed multi-channel impeller	4 = 200 mm 5 = 250 mm 6 = 300 mm 8 = 400 mm 10 = 500 mm	4 = 100 mm 5 = 130 mm 6 = 150 mm 165 mm 8 = 200 mm	(mm : 5) e.g. 80 = 400 mm	F, G, H, R, P3M	Motor with cooling jacket for dry installation  U = cooling of the medium		4 = 4-pole 6 = 6-pole 8 = 8-pole 10 = 10-pole 12 = 12-pole	S = stator chamber moisture monitoring	

## SERIES AND HYDRAULICS

### HYDRAULIC SELECTION

Discharge and suction connector:

- 3DN 200
- 3DN 250
- 3DN 300
- 3DN 400
- 3DN 500



### K(X)

Closed multi-channel impeller

For soiled and sludge-containing pumped media with solids.

Reducers for coupling systems and valves with different dimensions can be provided.

Impellers:

Various types of impellers are available for optimum matching to the operating conditions and the medium being handled.

Impeller passages:

Depending on pump type, 100 mm to 200 mm free ball passage.

# DESIGN – WELL THOUGHT OUT AT EVERY STAGE

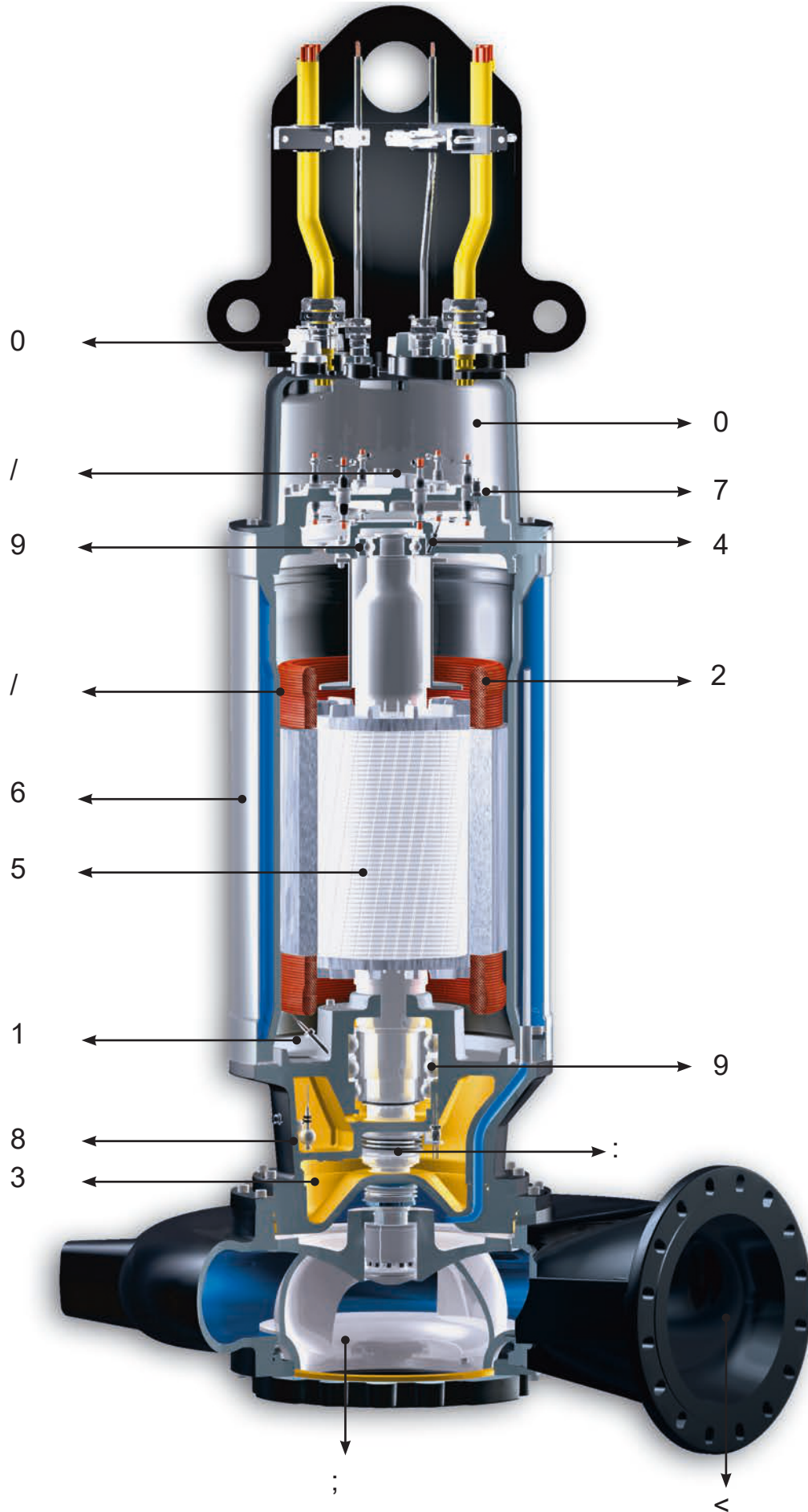

# SUPERIORMATERIAL QUALITY – LOWER SUSCEPTIBILITY TO FAILURE

Quality is a measurable value – fully floodable pump blocks from HOMA impress through their generous sizing of all important components, with outstanding material quality and solid mechanical workmanship.

## < DISCHARGE

With DIN flange DN 200 to DN 500 (PN 10).

## : BLOCKAGE-RESISTANT IMPELLERS

Closed multi-channel impeller with replaceable wear ring and large free passage

## : SHAFT SEAL

Two mechanical seals, acting independently of one another, arranged in tandem.

## 3 OIL CHAMBER

Oil filled sealing chamber with check-up option via inspection screw. All engines with seal monitoring in the oil chamber as standard.

## - MOTOR

Three-phase electric motors with 4-, 6-, 8-, 10- or 12-pole winding. Insulation class of winding H (180 °C), protection rating IP 68.

## EXPLOSION PROTECTION

All motors are also available as explosion-proof versions in accordance with Directive 2014/34/EU for equipment group II, category 2G, gas group IIB and temperature class T4(T3).

## - MOTOR COOLING

Motors in standard version with surface cooling in immersion operation. For dry installation or surface operation with cooling jacket, with open cooling circuit through the pumped medium (U version).

## 2 THERMAL SENSOR (BIMETALLIC)

As standard in the motor winding for temperature monitoring in all models. PTC thermistor or Pt100 on request.

## 8 MOISTURE MONITORING OF THE STATOR CHAMBER (S VERSION)

On request.

## 9 SHAFT BEARINGS

Robust, maintenance-free, permanently lubricated roller bearings.

## 4 TEMPERATURE MONITORING

of the shaft bearings on request.

## 1 JUNCTION CHAMBER

Encapsulated cable connection compartment, sealed against pressurised water. Except for P and PU versions.

## 7 ELECTRONIC MOISTURE SENSOR IN JUNCTION CHAMBER

Standard on P EX, F + F EX, G + G EX engines

## 0 CABLE INLET SEALED AGAINST PRESSURISED WATER

## / ANTI-CONDENSATION HEATER FOR CABLE JUNCTION CHAMBER AND STATOR CHAMBER

On request.

## MATERIALS

Motor housing	Grey cast iron EN-GJL-250 <sup>2)</sup>
Pump housing	Grey cast iron EN-GJL-250 <sup>2)</sup> Grey cast iron EN-GJL-400-15 <sup>1)</sup>
Impeller	Grey cast iron EN-GJL-250 <sup>2) 3)</sup> Grey cast iron EN-GJL-400-15 <sup>1)</sup>
Wear ring	Bronze/stainless steel
Motor shaft	Stainless steel
Mechanical seal	Silicon carbide/silicon carbide
Cooling jacket (with U and L versions)	Stainless steel
Elastomers	NBR (Perbunan) <sup>4)</sup>
Cable	H07RN-F (Plus) <sup>5)</sup>

1) On request; standard for DN 400 hydraulics or higher

2) Also available in stainless steel

3) Also available in bronze

4) Also in FPM (Viton)

5) Screened power cable on request

# DN 200/250 – SERIES– SELECTIONOVERVIEW

## DN 200

Closed two-channel  
impeller

100 mm Ø  
Ball passage  
1470 rpm



PAGE 14

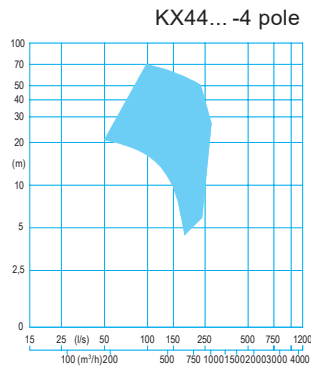

## DN 200

Closed two-channel  
impeller

100 mm Ø  
Ball passage  
960 rpm



PAGE 15

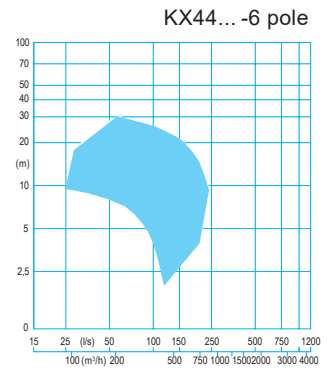

## DN 200

Closed two-channel  
impeller

100 mm Ø  
Ball passage  
680 rpm



PAGE 16

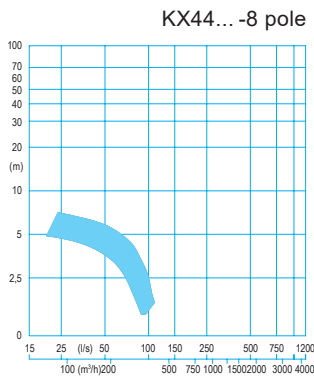

## DN 250

Closed two-channel  
impeller

125 mm Ø  
Ball passage  
960 rpm



PAGE 17

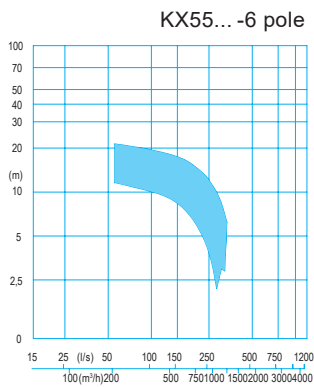

## DN 250

Closed two-channel  
impeller

125 mm Ø  
Ball passage  
710 rpm



PAGE 18

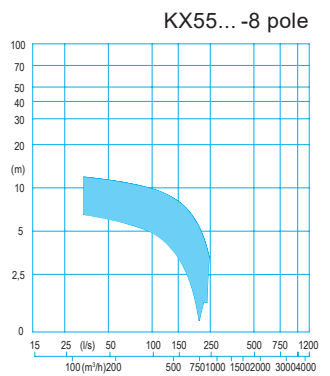

# DN 300/400/500 – SERIES– SELECTIONOVERVIEW

## DN 300

Closed two-channel  
impeller  
150 mm Ø  
Ball passage  
980 rpm



PAGE 19

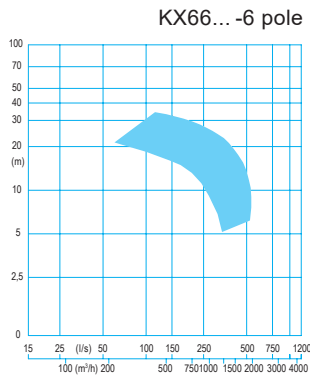

## DN 300

Closed two-channel  
impeller  
150 mm Ø  
Ball passage  
720 rpm



PAGE 20

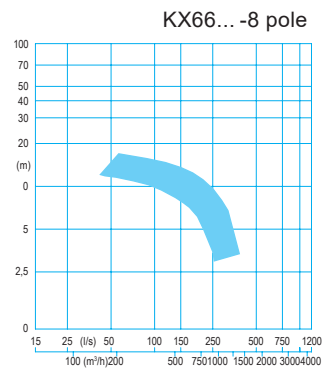

## DN 400

Closed two-channel  
impeller  
165 mm Ø  
Ball passage  
980 rpm



PAGE 21

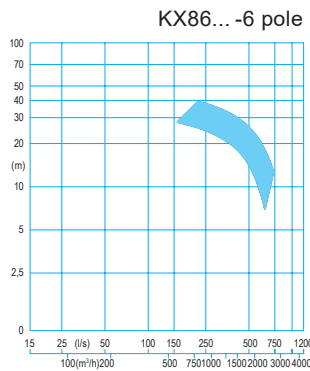

## DN 400

Closed two-channel  
impeller  
165 mm Ø  
Ball passage  
730 rpm



PAGE 22

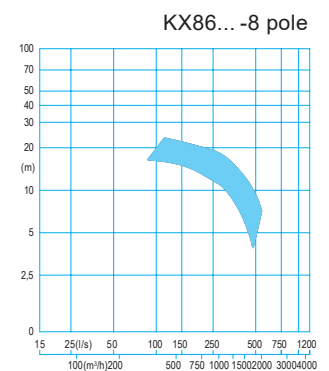

## DN 500

Closed two-channel  
impeller  
200 mm Ø  
Ball passage  
740 rpm



PAGE 23

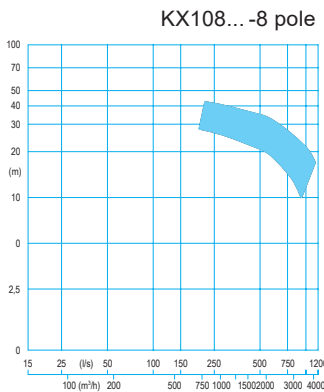

## DN 500

Closed two-channel  
impeller  
200 mm Ø  
Ball passage  
590 rpm



PAGE 24

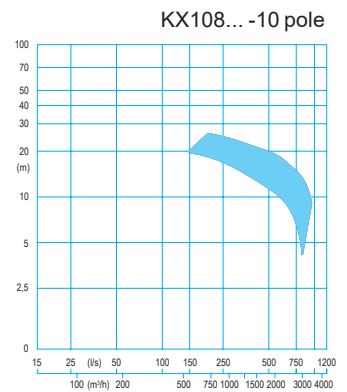

## DN 500

Closed two-channel  
impeller  
200 mm Ø  
Ball passage  
490 rpm



PAGE 25

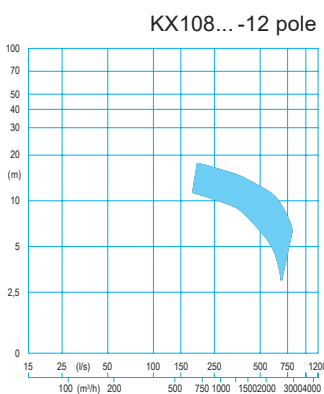

# DN 200 -KX 44...-4 POLE



Closed two-channel impeller

100 mm Ø ball passage

1450 rpm

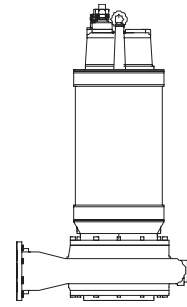

PUMP RATE

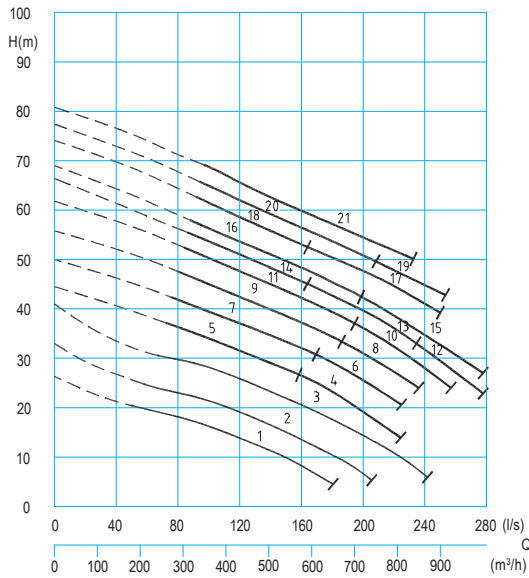

MOTOR INPUT

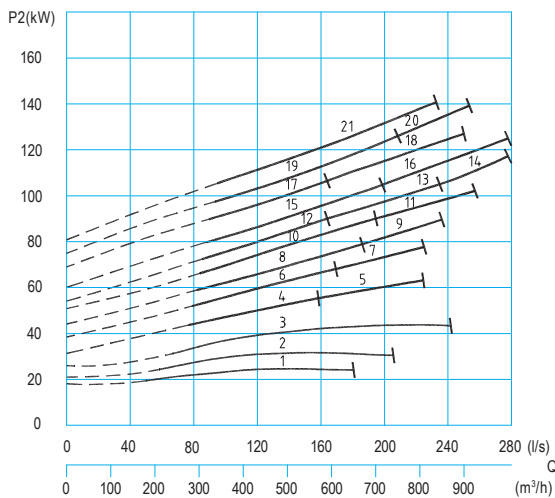

Technical data		WET WELL INSTALLATION			
Curve no.	Pump type	Motor input		Nominal current (A)	Standard weight (kg)
		P <sub>1</sub> (kW)	P <sub>2</sub> (kW)		
	KX 4458-F124 (S)(Ex)	29.133333325.6351.43475			
+	KX 4462-F144 (S)(Ex)	37.1333.0367.13485			
*	KX 4466-G174 (S)(Ex)	50.1346.1384.3			610
)	KX 4468-G194 (S)	61.033333356.53102.03576			
(	KX 4468-G214 (S)	75.0368.03130.03662			
'	KX 4472-G214 (S)	75.0368.03130.03670			
&	KX 4472-G224 (S)	85.0379.03140.73728			
%	KX 4476-G224 (S)	85.0379.03140.73735			
\$	KX 4476-H244 (S)	98.5390.03163.73895			
#	KX 4480-H244 (S)	98.5390.03163.73898			
"	KX 4480-H264 (S)	114.03105.03333188.43968			
!	KX 4483-H244 (S)	98.5390.03163.73900			
	KX 4483-H264 (S)	114.03105.03333188.43970			
	KX 4483-H284 (S)	138.03127.03231.43990			
	KX 4485-H264 (S)	114.03105.03188.431065			
•	KX 4485-H284 (S)	138.03127.03231.431085			
•	KX 4488-H264 (S)	114.03105.03188.431067			
•	KX 4488-H284 (S)	138.03127.03231.431087			
•	KX 4490-H284 (S)	138.03127.03231.431089			
•	KX 4490-H294 (S)	153.03141.03250.5			1109
Ⓣ	KX 4492-H294 (S)	153.03141.03250.5			1111

Technical data		DRY INSTALLATION			
Curve no.	Pump type	Motor input		Nominal current (A)	Standard weight (kg)
		P <sub>1</sub> (kW)	P <sub>2</sub> (kW)		
	KX 4458-FU124 (S)(Ex)	29.133333325.6351.43490			
+	KX 4462-FU144 (S)(Ex)	37.1333.0367.13500			
*	KX 4466-GU174 (S)(Ex)	50.1346.1384.33623			
)	KX 4468-GU194 (S)	61.0356.53102.0			601
(	KX 4468-GU214 (S)	75.0368.03130.03687			
'	KX 4472-GU214 (S)	75.0368.03130.03695			
&	KX 4472-GU224 (S)	85.0379.03140.73753			
%	KX 4476-GU224 (S)	85.0379.03140.73760			
\$	KX 4476-HU244 (S)	98.5390.03163.73930			
#	KX 4480-HU244 (S)	98.5390.03163.73933			
"	KX 4480-HU264 (S)	114.03105.03188.4			1003
!	KX 4483-HU244 (S)	98.5390.03163.73935			
	KX 4483-HU264 (S)	114.03105.03188.4			1005
	KX 4483-HU284 (S)	138.03127.03231.431025			
	KX 4485-HU264 (S)	114.03105.03188.4			1100
•	KX 4485-HU284 (S)	138.03127.03231.4			1120
•	KX 4488-HU264 (S)	114.03105.03188.4			1102
•	KX 4488-HU284 (S)	138.03127.03231.4			1122
•	KX 4490-HU284 (S)	138.03127.03231.4			1124
•	KX 4490-HU294 (S)	153.03141.03250.5			1144
Ⓣ	KX 4492-HU294 (S)	153.03141.03250.5			1146



# DN 200 -KX 44...-8 POLE



Closed two-channel impeller

100 mm Ø ball passage

680 rpm

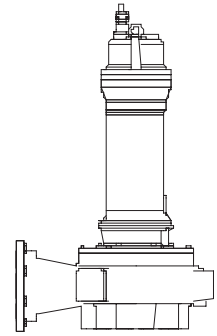

PUMP RATE

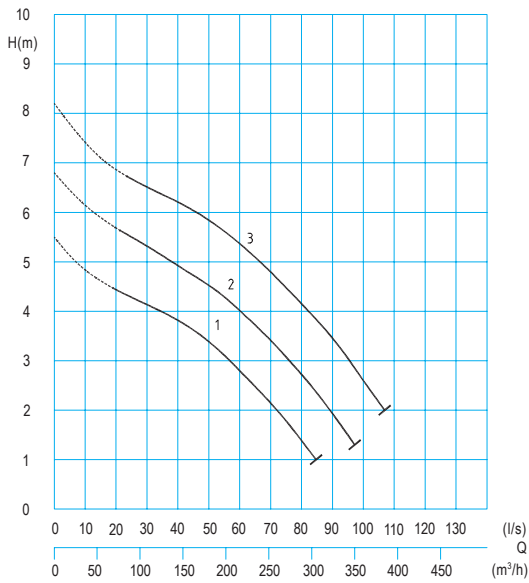

## Technical data

## WET WELL INSTALLATION

Curve/Pump type no.	Motor input		Nominal current (A)	Standard weight (kg)
	P <sub>1</sub> (kW)	P <sub>2</sub> (kW)		
3 KX 4458-P68 (Ex)	7.2	5.63333333	13.5	310
2 KX 4462-P68 (Ex)	7.2	5.63333333	13.5	310
1 KX 4466-P68 (Ex)	7.2	5.63333333	13.5	310

MOTOR INPUT

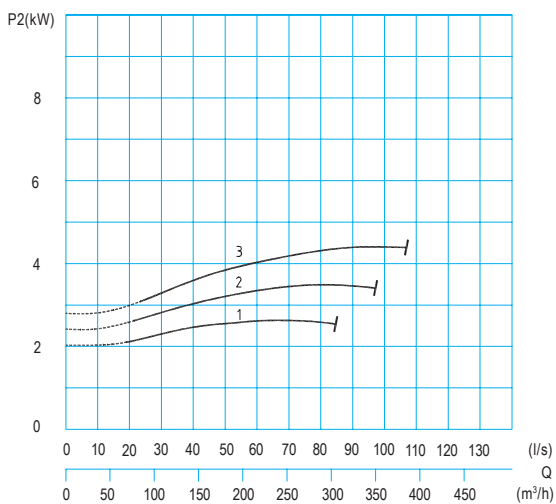

## Technical data

## DRY INSTALLATION

Curve/Pump type no.	Motor input		Nominal current (A)	Standard weight (kg)
	P <sub>1</sub> (kW)	P <sub>2</sub> (kW)		
3 KX 4458-PU68 (Ex)	7.2	5.63333333	13.5	533333333333320
2 KX 4462-PU68 (Ex)	7.2	5.63333333	13.5	533333333333320
1 KX 4466-PU68 (Ex)	7.2	5.63333333	13.5	533333333333320



# DN 250 -KX 55...-6 POLE



## Closed two-channel impeller

125mm Ø ball passage

960 rpm

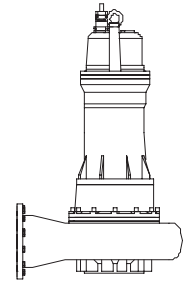

PUMP RATE

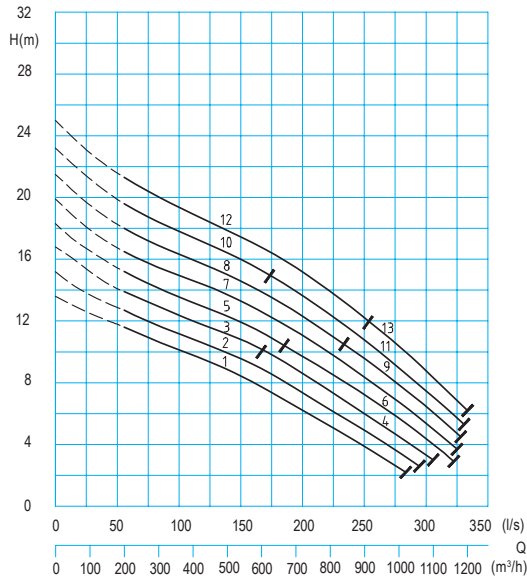

### Technical data

### WET WELL INSTALLATION

Curve no.	Pump type	Motor input P <sub>1</sub> (kW)	Nominal current P <sub>2</sub> (A)	Standard weight (kg)
,	KX 5568-F106 (S)(Ex)	22,5319	5341,2	550
+	KX 5570-F116 (S)(Ex)	26,0322	6348,3	569
*	KX 5572-F116 (S)(Ex)	26,0322	6348,3	569
)	KX 5572-F126 (S)(Ex)	29,5325	8355,5	585
(	KX 5574-F126 (S)(Ex)	29,5325	8355,5	585
'	KX 5574-G136 (S)(Ex)	37,0333	233333367,5	709
&	KX 5576-G136 (S)(Ex)	37,0333	233333367,5	709
%	KX 5578-G136 (S)(Ex)	37,0333	233333367,5	709
\$	KX 5578-G156 (S)(Ex)	45,0340	533333382,0	745
#	KX 5580-G136 (S)(Ex)	37,0333	233333367,5	709
"	KX 5580-G156 (S)(Ex)	45,0340	533333382,0	745
!	KX 5582-G156 (S)(Ex)	45,0340	533333382,0	745
!	KX 5582-G176 (S)	55,0349	53100,0	803

MOTOR INPUT

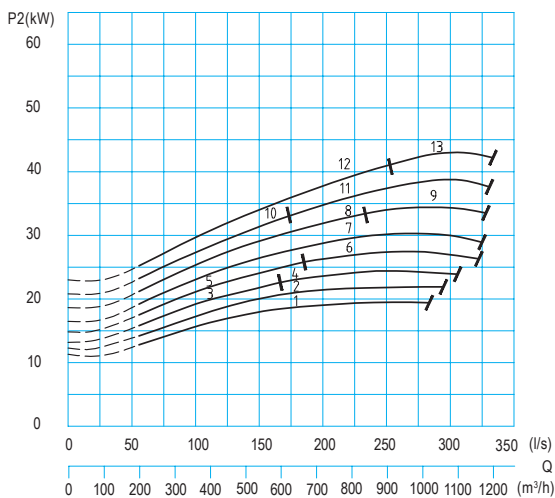

### Technical data

### DRY INSTALLATION

Curve no.	Pump type	Motor input P <sub>1</sub> (kW)	Nominal current P <sub>2</sub> (A)	Standard weight (kg)
,	KX 5568-FU106 (S)(Ex)	22,5319	5341,2	567
+	KX 5570-FU116 (S)(Ex)	26,0322	6348,3	586
*	KX 5572-FU116 (S)(Ex)	26,0322	6348,3	586
)	KX 5572-FU126 (S)(Ex)	29,5325	8355,5	602
(	KX 5574-FU126 (S)(Ex)	29,5325	8355,5	602
'	KX 5574-GU136 (S)(Ex)	37,0333	233333367,5	717
&	KX 5576-GU136 (S)(Ex)	37,0333	233333367,5	717
%	KX 5578-GU136 (S)(Ex)	37,0333	233333367,5	717
\$	KX 5578-GU156 (S)(Ex)	45,0340	533333382,0	753
#	KX 5580-GU136 (S)(Ex)	37,0333	233333367,5	717
"	KX 5580-GU156 (S)(Ex)	45,0340	533333382,0	753
!	KX 5582-GU156 (S)(Ex)	45,0340	533333382,0	753
!	KX 5582-GU176 (S)	55,0349	53100,0	815

# DN 250 -KX55...-8 POLE



Closed two-channel impeller

125 mm Ø ball passage

710 rpm

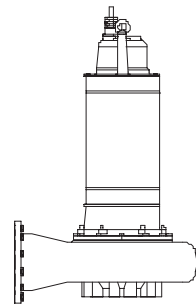

PUMP RATE

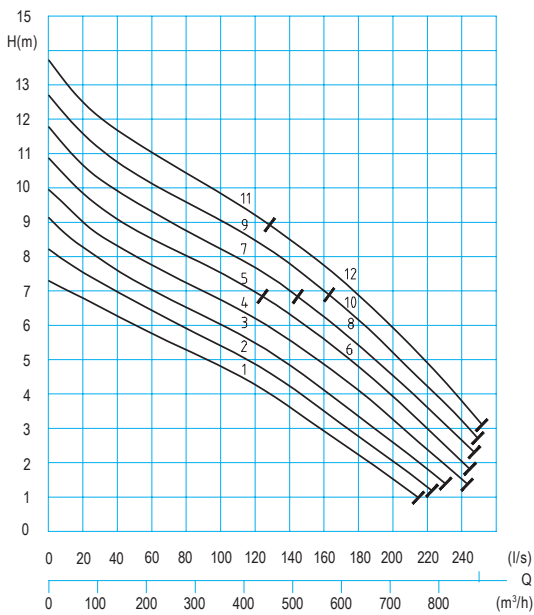

### Technical data

Curve no.	Pump type	WET WELL INSTALLATION		
		Motor input P <sub>1</sub> (kW)	Nominal P <sub>2</sub> current (A)	Standard weight (kg)
,	KX 5568-F78 (S)	13,0	11,0326,1	521
+	KX 5570-F78 (S)	13,0	11,0326,1	521
*	KX 5572-F78 (S)	13,0	11,0326,1	521
)	KX 5574-F78 (S)	13,0	11,0326,1	521
(	KX 5576-F78 (S)	13,0	11,0326,1	521
'	KX 5576-F88 (S)	15,0312,7329,8		523
&	KX 5578-F88 (S)	15,0312,7329,8		523
%	KX 5578-F98 (S)	17,033333314,4333,8		554
\$	KX 5580-F98 (S)	17,033333314,4333,8		554
#	KX 5580-F108 (S)	19,5316,6338,9		-
"	KX 5582-F98 (S)	17,033333314,4333,8		554
!	KX 5582-F118 (S)	22,0318,7343,2		-

MOTOR INPUT

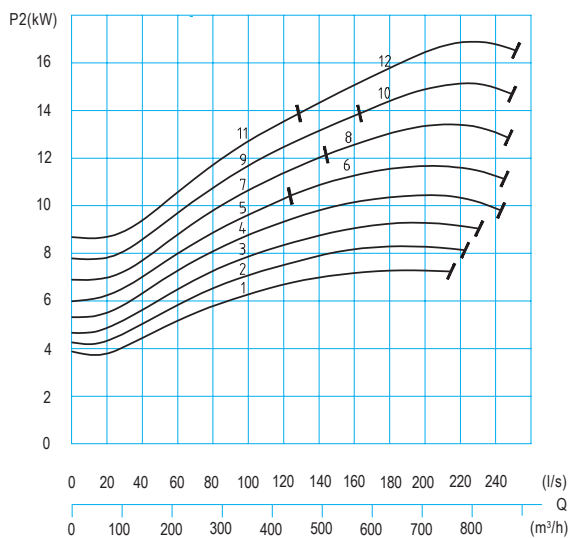

### Technical data

Curve no.	Pump type	DRY INSTALLATION		
		Motor input P <sub>1</sub> (kW)	Nominal P <sub>2</sub> current (A)	Standard weight (kg)
,	KX 5568-FU78 (S)	13,0	11,0326,1	535
+	KX 5570-FU78 (S)	13,0	11,0326,1	535
*	KX 5572-FU78 (S)	13,0	11,0326,1	535
)	KX 5574-FU78 (S)	13,0	11,0326,1	535
(	KX 5576-FU78 (S)	13,0	11,0326,1	535
'	KX 5576-FU88 (S)	15,0312,7329,8		537
&	KX 5578-FU88 (S)	15,0312,7329,8		537
%	KX 5578-FU98 (S)	17,033333314,4333,8		572
\$	KX 5580-FU98 (S)	17,033333314,4333,8		572
#	KX 5580-FU108 (S)	19,5316,6338,9		-
"	KX 5582-FU98 (S)	17,033333314,4333,8		572
!	KX 5582-FU118 (S)	22,0318,7343,2		-

# DN 300 -KX 66...-6 POLE



Closed two-channel impeller

150 mm Ø ball passage

960 rpm

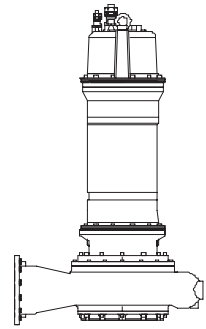

PUMP RATE

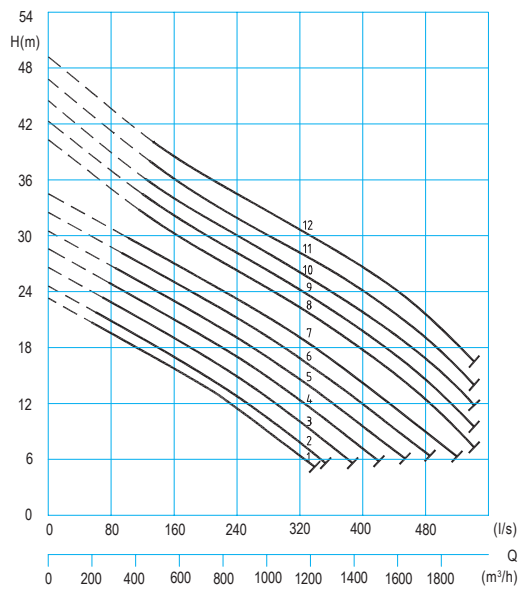

### Technical data

### WET WELL INSTALLATION

Curve\Pump type no.	Motor input			Standard weight (kg)
	P <sub>1</sub> (kW)	P <sub>2</sub> (kW)	Nominal current (A)	
, KX 6678-G156 (S)(Ex)	45.0340	5382.1	13826	
+ KX 6680-G176 (S)	55.0349	5399.7	73892	
* KX 6683-G176 (S)	55.0349	5399.7	73893	
) KX 6686-G196 (S)	64.0358	03118.0	033333333333958	
( KX 6689-H216 (S)	75.3368	53333138.0	031024	
' KX 6692-H216 (S)	75.3368	53333138.0	031026	
& KX 6695-H236 (S)	90.3382	03333166.0	031092	
% KX 6698-H256 (S)	107.7398	03196.0	031230	
\$ KX 66100-H276 (S)(Ex)	123.13112	03227.0	031320	
# KX 66102-H276 (S)(Ex)	123.13112	03227.0	031320	
" KX 66104-R286 (S)(Ex)	140.43132	03241.0	0333333331830	
! KX 66106-R316 (S)(Ex)	168.43160	03287.0	031870	

MOTOR INPUT

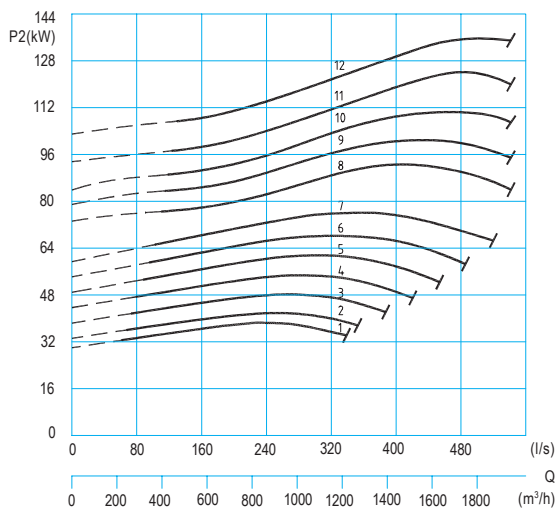

### Technical data

### DRY INSTALLATION

Curve\Pump type no.	Motor input			Standard weight (kg)
	P <sub>1</sub> (kW)	P <sub>2</sub> (kW)	Nominal current (A)	
, KX 6678-GU156 (S)(Ex)	45.0340	5382.1	13906	
+ KX 6680-GU176 (S)	55.0349	5399.7	73972	
* KX 6683-GU176 (S)	55.0349	5399.7	73973	
) KX 6686-GU196 (S)	64.033333358	03118.0	031038	
( KX 6689-HU216 (S)	75.3368	53138.0	1124	
' KX 6692-HU216 (S)	75.3368	53138.0	1126	
& KX 6695-HU236 (S)	90.3382	03166.0	1192	
% KX 6698-HU256 (S)	107.7398	03196.0	031330	
\$ KX 66100-HU276 (S)(Ex)	123.13112	03227.0	031420	
# KX 66102-HU276 (S)(Ex)	123.13112	03227.0	031420	
" KX 66104-RU286 (S)(Ex)	140.43132	03241.0	0333333331940	
! KX 66106-RU316 (S)(Ex)	168.43160	03287.0	031980	

# DN 300 -KX 66...-8 POLE



Closed two-channel impeller

150 mm Ø ball passage

720 rpm

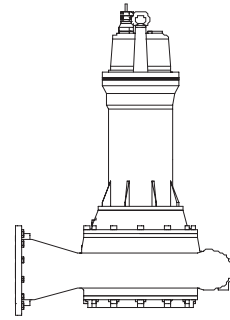

PUMP RATE

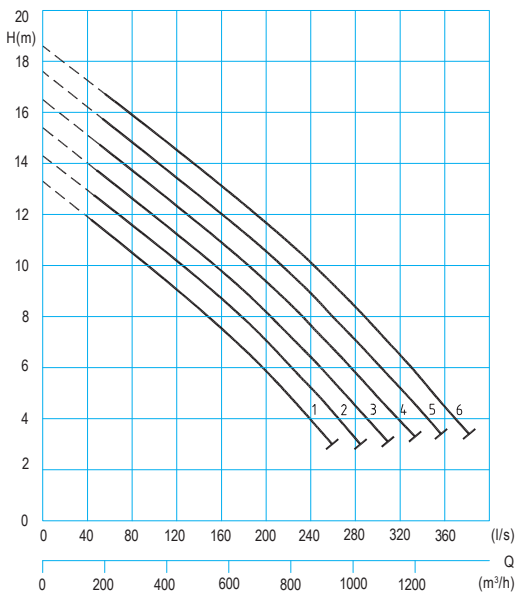

### Technical data

Curve/Pump type no.	WET WELL INSTALLATION		
	Motor input P <sub>1</sub> (kW)	Nominal current P <sub>2</sub> (A)	Standard weight (kg)
, KX 6680-G128 (S)	28.5325	0.33806	
+ KX 6683-G128 (S)	28.5325	0.33808	
* KX 6686-G128 (S)	28.5325	0.33808	810
) KX 6689-G128 (S)	28.5325	0.33808	812
( KX 6692-G148 (S)	35.0331	0.33834	
' KX 6695-G148 (S)	35.0331	0.33835	

MOTOR INPUT

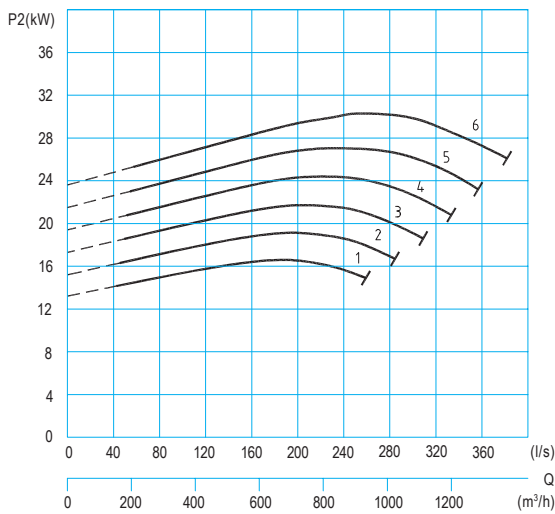

### Technical data

Curve/Pump type no.	DRY INSTALLATION		
	Motor input P <sub>1</sub> (kW)	Nominal current P <sub>2</sub> (A)	Standard weight (kg)
, KX 6680-GU128 (S)	28.5325	0.33886	
+ KX 6683-GU128 (S)	28.5325	0.33888	
* KX 6686-GU128 (S)	28.5325	0.33890	
) KX 6689-GU128 (S)	28.5325	0.33892	
( KX 6692-GU148 (S)	35.0331	0.33871	914
' KX 6695-GU148 (S)	35.0331	0.33871	915

# DN 400 -KX 86...-6 POLE



Closed two-channel impeller

165 mm Ø ball passage

980 rpm

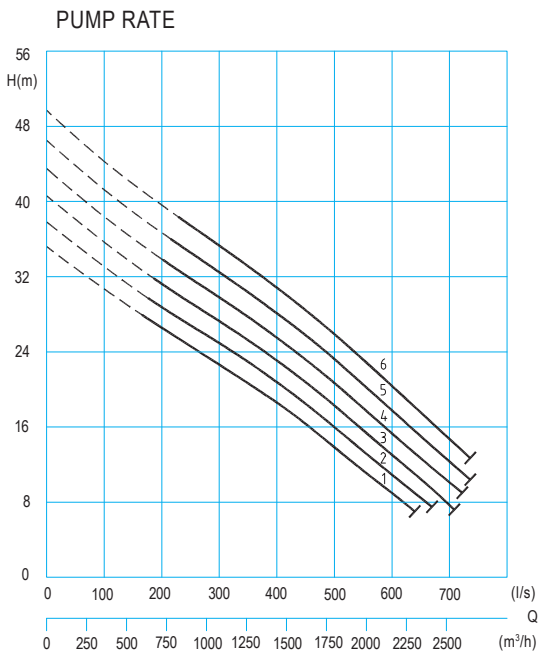
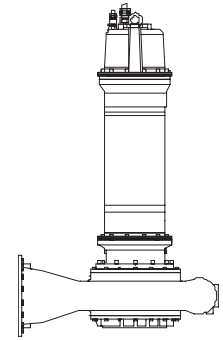

Technical data		WET WELL INSTALLATION		
Curve no.	Pump type	Motor input P <sub>1</sub> (kW)	Nominal current (A)	Standard weight (kg)
,	KX 86100-H276 (S)(Ex)	123.53112.03227	0.31602	
+	KX 86102-H276 (S)(Ex)	123.53112.03227	0.31605	
*	KX 86104-R286 (S)(Ex)	140.03132.03241	0	2110
)	KX 86106-R316 (S)(Ex)	169.03160.03287	0.32150	
(	KX 86108-R316 (S)(Ex)	169.03160.03287	0.32153	
'	KX 86110-R346 (S)(Ex)	195.03185.03337	0.32355	

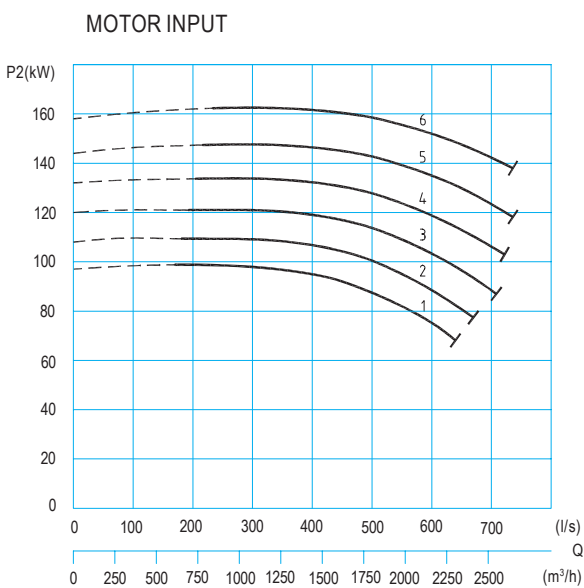

Technical data		DRY INSTALLATION		
Curve no.	Pump type	Motor input P <sub>1</sub> (kW)	Nominal current (A)	Standard weight (kg)
,	KX 86100-HU276 (S)(Ex)	123.53112.03227	0.31702	
+	KX 86102-HU276 (S)(Ex)	123.53112.03227	0.31705	
*	KX 86104-RU286 (S)(Ex)	140.03132.03241	0.32220	
)	KX 86106-RU316 (S)(Ex)	169.03160.03287	0.32260	
(	KX 86108-RU316 (S)(Ex)	169.03160.03287	0.32263	
'	KX 86110-RU346 (S)(Ex)	195.03185.03337	0.32465	

# DN 400 -KX 86...-8 POLE



Closed two-channel impeller

165 mm Ø ball passage

730 rpm

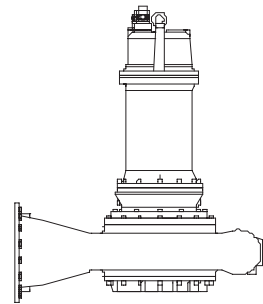

PUMP RATE

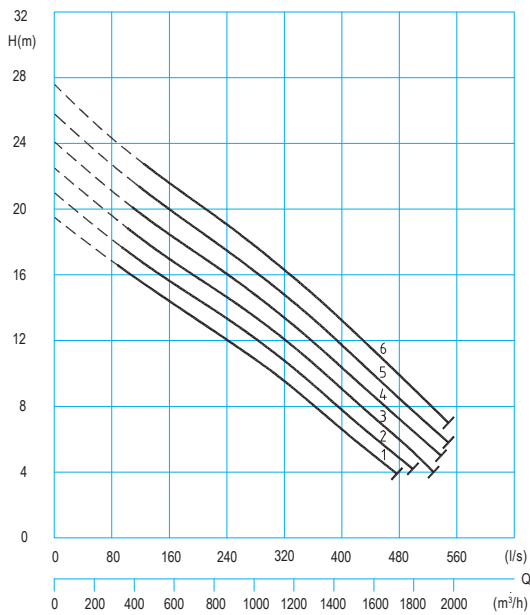

### Technical data

Curve no.	Pump type	WET WELL INSTALLATION		
		Motor input P <sub>1</sub> (kW)	Nominal current (A)	Standard weight (kg)
,	KX 86100-H178 (S)	49.5345.0393.931550		
+	KX 86102-H178 (S)	49.5345.0393.931550		
*	KX 86104-H198 (S)	58.5353.03109.931582		
)	KX 86106-H208 (S)	70.0363.03129.6		1614
(	KX 86108-H208 (S)	70.0363.03129.6		1617
'	KX 86110-H228 (S)	79.0372.03148.231656		

MOTOR INPUT

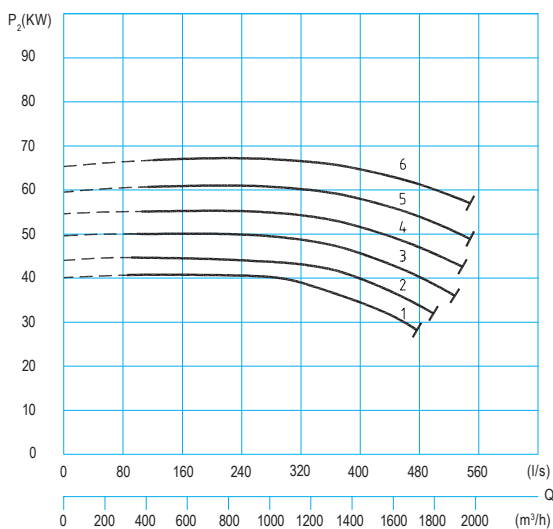

### Technical data

Curve no.	Pump type	DRY INSTALLATION		
		Motor input P <sub>1</sub> (kW)	Nominal current (A)	Standard weight (kg)
,	KX 86100-HU178 (S)	49.5345.0393.931650		
+	KX 86102-HU178 (S)	49.5345.0393.931652		
*	KX 86104-HU198 (S)	58.5353.03109.931682		
)	KX 86106-HU208 (S)	70.0363.03129.6		1714
(	KX 86108-HU208 (S)	70.0363.03129.6		1717
'	KX 86110-HU228 (S)	79.0372.03333148.231756		

# DN 500 -KX 108...-8 POLE



Closed two-channel impeller

200 mm Ø ball passage

740 rpm

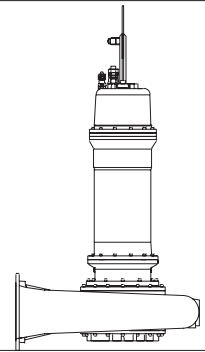

PUMP RATE

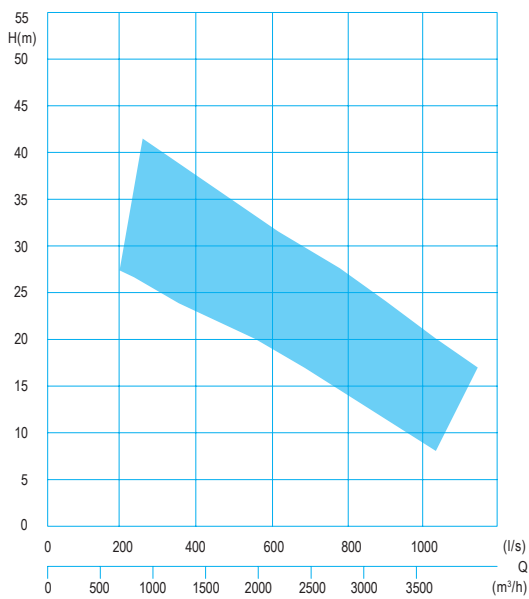

## Technical data

Please get in touch to request information about the technical data of individual pump types.

MOTOR INPUT

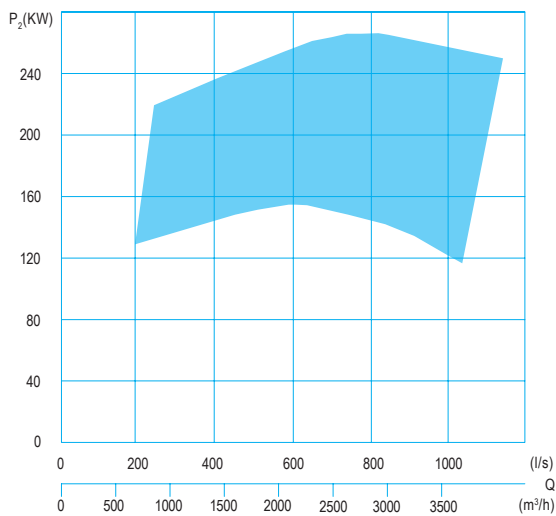

# DN 500 -KX 108...-10 POLE



**Closed two-channel impeller**

200 mm Ø ball passage

590 rpm

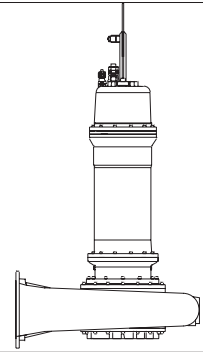

**PUMP RATE**

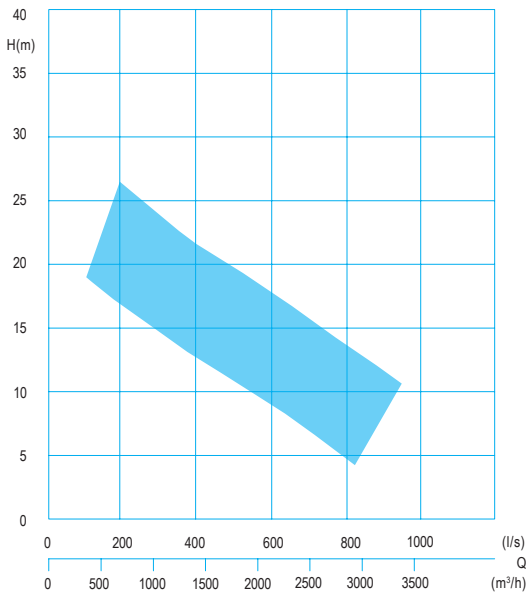

## Technical data

Please get in touch to request information about the technical data of individual pump types.

**MOTOR INPUT**

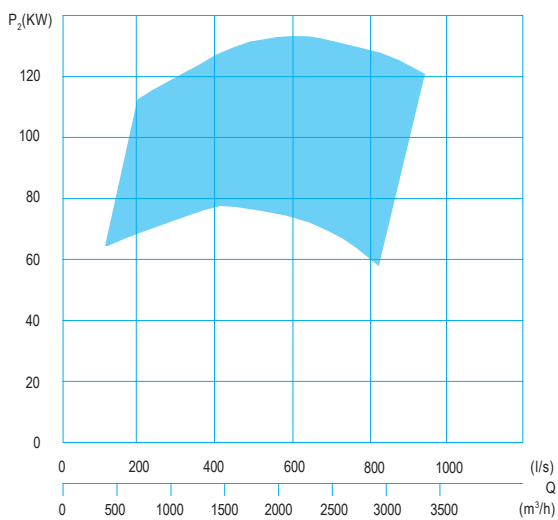



# DN 500 -KX 108...-12 POLE



Closed two-channel impeller  
 200 mm Ø ball passage  
 490 rpm

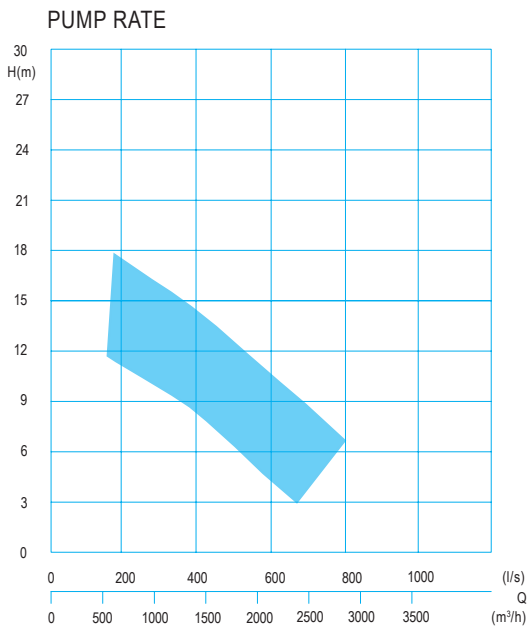
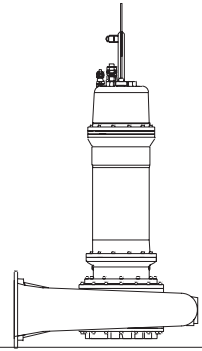

**Technical data**  
 Please get in touch to request information about the technical data of individual pump types.

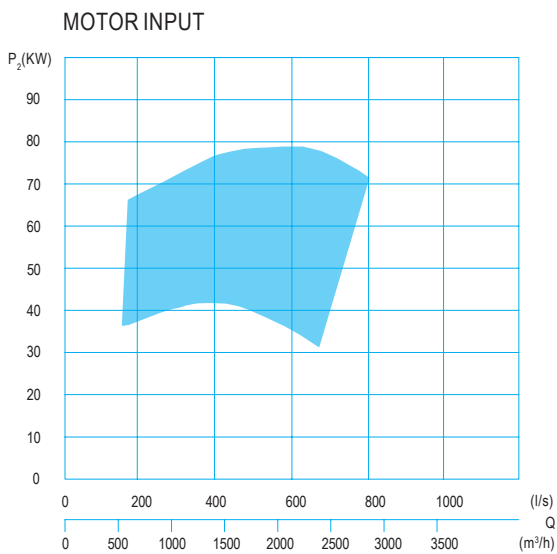

# ACCESSORIES

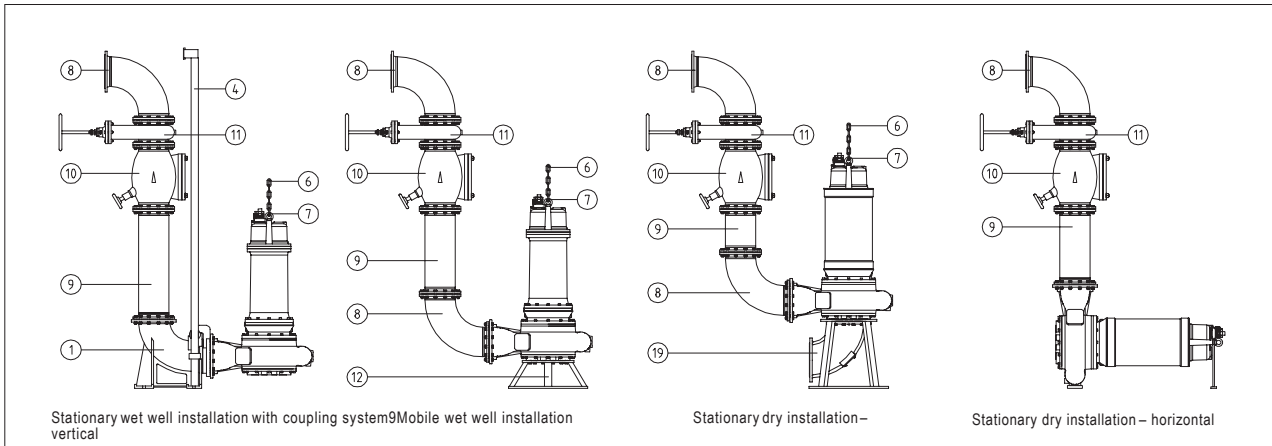

No.&Description	Model&Size	Art. no.	
• Automatic coupling system, comprising coupling base bend, coupling mating flange and upper guide bracket	KK 200/200 KK 250/200 KK 250/250 KK 300/250 KK 300/300 KK 400/350 KK 400/400	DN 200 DN 250 / DN 200 DN 250 DN 300 / DN 250 DN 300 DN 400 / DN 350 DN 400	8604100.01 8604120.01 8604110 8604130 8604090 8604144 8604140
; Automatic coupling system, comprising coupling base, coupling mating flange and upper guide bracket	KS 200/200 KS 250/250	DN 200 DN 250	8604081 8604085
Intermediate bracket for guide pipe extension - Grey cast iron		2½" for DN 200 and DN 250 2½" for DN 300 3" for DN 400	7322911 7322921 7323935
3 Guide pipes – in pairs, by the metre  Version (material): - Zinc-plated steel		2" 2½" 3"	2190205 2190225 2190230
- Stainless steel		2" 2½" 3"	2190256 2190258 2190260
- Pump chain set - Single row, tested, load bearing capacity up to 320 kg Pitch 984 mm, 4x12 with shackle		2 m 3 m 4 m 5 m 6 m 8 m	2800362.02 2800362.03 2800364.04 2800362.05 2800362.06 2800362.08
Pump chain set - Dual row, tested, load bearing capacity up to 320 kg Pitch 984 mm, 4x12 with shackle		4 m 5 m 6 m 8 m	2800367.04 2800367.05 2800367.06 2800367.08
Pump chain set - Dual row, tested, load bearing capacity up to 560 kg Pitch 943 mm, 5x15 with shackle		4 m 6 m	2800365.04 2800365.06
Pump chain set - Dual row, tested, load bearing capacity up to 850 kg Pitch 998 mm, 6x18 with shackle		6 m	2800366.06
8 90° pipe bend -With 2 flanges, 1 set of screws and gasket		DN 200 DN 250 DN 300 DN 400	2153363 2153373 2153383 On request
8 90° pipe bend with cleaning aperture -With 2 flanges, 1 set of screws and gasket		DN 200 DN 200/250 DN 250 DN 250/300 DN 300 DN 400	On request

# ACCESSORIES

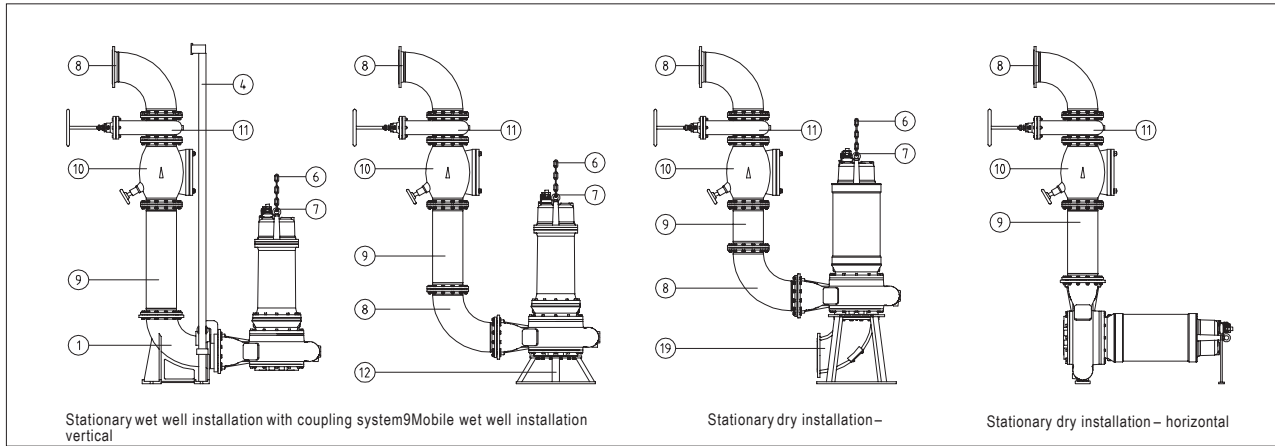

No. & Description	Model & Size	Art. no.	
- Or connection piece for pressure pipe in double pump station with 3 flanges, horizontal outlet (also available with vertical outlet) with screws and gasket	DN 200 DN 250 DN 300 DN 400	On request	
9 Pressure pipe - With 2 flanges, 1 m long, 1 set of screws and gasket	DN 200 DN 250 DN 300 DN 400	2150200 2150250 2150300 On request	
Pressure pipe - Extension, by the metre	DN 200 DN 250 DN 300 DN 400	On request	
- Reducer, with 2 flanges		On request	
4 Non-return valve GG - With flanges, grey cast iron	DN 200 DN 250 DN 300 DN 350 DN 400	2212816 2216817 2216818 On request On request	
1 Shut-off gate valve - With flanges, grey cast iron	DN 200 DN 250 DN 300 DN 400	2216200 2216250 2216300 On request	
7 Base support ring	NB 200 NB 250 NB 300 NB 350 NB 400	DN 200 DN 250 DN 300 DN 350 DN 400	7321295 7321675 7321665 On request On request
• Pump stand for vertical dry installation with 90° suction pipe bend with cleaning aperture (DN 200- DN 500)	TVS 200 R TVS 200/250 R TVS 250 R TVS 250/300 R TVS 300 R TVS 350 TVS 400 R	DN 200 DN 200/250 DN 250 DN 250/300 DN 300 DN 350 DN 400	8604240 8604245 8604250 8604255 8604260 8604265 On request
Mounting plate for vertical dry installation on concrete plinth with 90° suction pipe bend	TVM 350 TVM 400	DN 350 DN 400	On request On request
Set of screws (8 pce) with gasket - Zinc-plated		DN 200 DN 250 DN 300	2214200 2214250 2214300
- Stainless steel		DN 200 DN 250 DN 300	2214202 2214252 2214302

Coupling systems, pipe bends, pipes, valves (gate valves, dampers, valves) made from stainless steel on request. See special brochures for electrical and electronic control systems for pumps and pump stations, fully pre-assembled, with accessories. See special brochures for waste water sumps made from concrete or plastic for complete pump stations. Pump housing with cleaning aperture on request. DN 500 accessories on request.